

SULIT

3472/1

Matematik Tambahan

Kertas 1

Ogos 2012

2 jam

Nama :

Tingkatan:



**PERSIDANGAN KEBANGSAAN PENGETUA-PENGETUA
SEKOLAH MENENGAH MALAYSIA (PKPSM) CAWANGAN MELAKA
PEPERIKSAAN PERCUBAAN SIJIL PELAJARAN MALAYSIA 2012**

MATEMATIK TAMBAHAN

Kertas 1

Dua Jam

JANGAN BUKA KERTAS SOALAN INI SEHINGGA DIBERITAHU

- This question paper consists of 25 questions***
Kertas soalan ini mengandungi 25 soalan.
- Answer all questions.***
Jawab semua soalan.
- Give only one answer for each question***
Bagi setiap soalan berikan SATU jawapan sahaja.
- Write the answers clearly in the space provided in the question paper***
Jawapan hendaklah ditulis pada ruang yang disediakan dalam kertas soalan.
- Show your working. It may help you to get marks.***
Tunjukkan langkah-langkah penting dalam kerja mengira anda. Ini boleh membantu anda untuk mendapatkan markah.
- If you wish to change your answer, cross out the work that you have done. Then write down the new answer.***
Sekiranya anda hendak menukar jawapan, batalkan kerja mengira yang telah dibuat. Kemudian tulis jawapan yang baru.
- The diagram in the questions provided are not drawn to scale unless stated.***
Rajah yang mengiringi soalan ini tidak dilukiskan mengikut skala kecuali dinyatakan.
- The marks allocated for each question and sub-part of a question are shown in brackets.***
Markah yang diperuntukkan bagi setiap soalan atau ceraihan soalan ditunjukkan dalam kurungan.
- A list of formulae is provided on page 2 to 3***
Satu senarai rumus disediakan di halaman 23 hingga 3
- You may use a non-programmable scientific calculator.***
Buku sifir matematik empat angka boleh digunakan.
- This question paper must be handed in at the end of the examination.***
Kertas soalan ini hendaklah diserahkan pada akhirpeperiksaan .

Kod Pemeriksa		
Soalan	Markah Penuh	Markah Diperoleh
1	3	
2	3	
3	2	
4	3	
5	3	
6	3	
7	3	
8	4	
9	4	
10	3	
11	3	
12	3	
13	2	
14	3	
15	3	
16	3	
17	4	
18	4	
19	4	
20	3	
21	3	
22	4	
23	4	
24	3	
25	3	
Jumlah	80	

Kertas soalan ini mengandungi 22 halaman bercetak

SULIT

The following formulae may be helpful in answering the questions. The symbols given are the ones commonly used.

Rumus-rumus berikut boleh digunakan untuk membantu anda menjawab soalan. . Simbol-simbol yang diberi adalah yang biasa digunakan.

ALGEBRA

$$1 \quad x = \frac{-b \pm \sqrt{b^2 - 4ac}}{2a}$$

$$2 \quad a^m \times a^n = a^{m+n}$$

$$3 \quad a^m \div a^n = a^{m-n}$$

$$4 \quad (a^m)^n = a^{nm}$$

$$5 \quad \log_a mn = \log_a m + \log_a n$$

$$6 \quad \log_a \frac{m}{n} = \log_a m - \log_a n$$

$$7 \quad \log_a m^n = n \log_a m$$

$$8 \quad \log_a b = \frac{\log_c b}{\log_c a}$$

$$9 \quad T_n = a + (n-1)d$$

$$10 \quad S_n = \frac{n}{2}[2a + (n-1)d]$$

$$11 \quad T_n = ar^{n-1}$$

$$12 \quad S_n = \frac{a(r^n - 1)}{r - 1} = \frac{a(1 - r^n)}{1 - r}, \quad (r \neq 1)$$

$$13 \quad S_\infty = \frac{a}{1 - r}, \quad |r| < 1$$

CALCULUS (KALKULUS)

$$1 \quad y = uv, \quad \frac{dy}{dx} = u \frac{dv}{dx} + v \frac{du}{dx}$$

$$2 \quad y = \frac{u}{v}, \quad \frac{dx}{dy} = \frac{v \frac{du}{dx} - u \frac{dv}{dx}}{v^2}$$

$$3 \quad \frac{dy}{dx} = \frac{dy}{du} \times \frac{du}{dx}$$

4 Area under a curve (Luas dibawah lengkung)

$$= \int_a^b y \, dx \quad \text{or}$$
$$= \int_a^b x \, dy$$

5 Volume generated (Isipadu Janaan)

$$= \int_a^b \pi y^2 \, dx \quad \text{or}$$
$$= \int_a^b \pi x^2 \, dy$$

GEOMETRY

$$1 \quad \text{Distance (Jarak)} = \sqrt{(x_1 - x_2)^2 + (y_1 - y_2)^2}$$

2 Midpoint (Titik Tengah)

$$(x, y) = \left(\frac{x_1 + x_2}{2}, \frac{y_1 + y_2}{2} \right)$$

$$3 \quad |r| = \sqrt{x^2 + y^2}$$

$$4 \quad \hat{r} = \frac{xi + yj}{\sqrt{x^2 + y^2}}$$

5 A point dividing a segment of a line
Titik yang membahagi suatu tembereng garis

$$(x, y) = \left(\frac{nx_1 + mx_2}{m+n}, \frac{ny_1 + my_2}{m+n} \right)$$

6 Area of triangle (Luas Segitiga)

$$\frac{1}{2} |(x_1 y_2 + x_2 y_3 + x_3 y_1) - (x_2 y_1 + x_3 y_2 + x_1 y_3)|$$

STATISTICS

$$1 \quad \bar{x} = \frac{\sum x}{N}$$

$$2 \quad \bar{x} = \frac{\sum fx}{\sum f}$$

$$3 \quad \sigma = \sqrt{\frac{\sum (x - \bar{x})^2}{N}} = \sqrt{\frac{\sum x^2}{N} - \bar{x}^2}$$

$$4 \quad \sigma = \sqrt{\frac{\sum f(x - \bar{x})^2}{\sum f}} = \sqrt{\frac{\sum fx^2}{\sum f} - \bar{x}^2}$$

$$5 \quad m = L + \left[\frac{\frac{1}{2}N - F}{f_m} \right] C$$

$$6 \quad I = \frac{Q_1}{Q_0} \times 100$$

$$7 \quad \bar{I} = \frac{\sum w_1 I_1}{\sum w_1}$$

$$8 \quad {}^n P_r = \frac{n!}{(n-r)!}$$

$$9 \quad {}^n C_r = \frac{n!}{(n-r)!r!}$$

$$10 \quad P(A \cup B) = P(A) + P(B) - P(A \cap B)$$

$$11 \quad P(X=r) = {}^n C_r p^r q^{n-r}, p+q=1$$

$$12 \quad \text{Mean } \mu = np$$

$$13 \quad \sigma = \sqrt{npq}$$

$$14 \quad z = \frac{x - \mu}{\sigma}$$

TRIGONOMETRY

$$1 \quad \text{Arc length, } s = r\theta$$

(Panjang lengkok) $s = j\theta$

$$2 \quad \text{Area of sector, } L = \frac{1}{2}r^2\theta$$

$$(Luas sektor) L = \frac{1}{2}j^2\theta$$

$$3 \quad \sin^2 A + \cos^2 A = 1$$

$$4 \quad \sec^2 A = 1 + \tan^2 A$$

$$5 \quad \text{cosec}^2 A = 1 + \cot^2 A$$

$$6 \quad \sin 2A = 2 \sin A \cos A$$

$$7 \quad \begin{aligned} \cos 2A &= \cos^2 A - \sin^2 A \\ &= 2 \cos^2 A - 1 \\ &= 1 - 2 \sin^2 A \end{aligned}$$

$$8 \quad \tan 2A = \frac{2 \tan A}{1 - \tan^2 A}$$

$$9 \quad \sin(A \pm B) = \sin A \cos B \pm \cos A \sin B$$

$$10 \quad \cos(A \pm B) = \cos A \cos B \mp \sin A \sin B$$

$$11 \quad \tan(A \pm B) = \frac{\tan A \pm \tan B}{1 \mp \tan A \tan B}$$

$$12 \quad \frac{a}{\sin A} = \frac{b}{\sin B} = \frac{c}{\sin C}$$

$$13 \quad a^2 = b^2 + c^2 - 2bc \cos A$$

$$14 \quad \text{Area of triangle} = \frac{1}{2}ab \sin C$$

(Luas Segitiga)

For
examiner's
use only

Answer **all** questions.
Jawab **semua** soalan

- 1 Diagram 1 shows the linear function f .
Rajah 1 menunjukkan fungsi linear f .

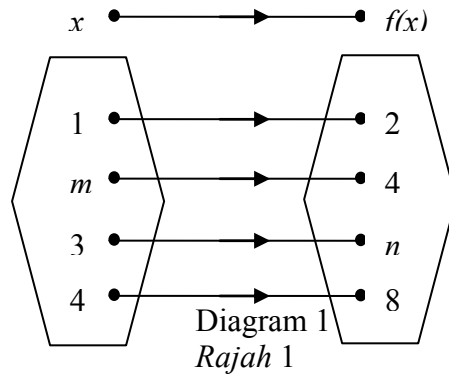

State:
Nyatakan:

- value of m
nilai m
- value of n
nilai n
- image of 10
imej bagi 10

[3 marks]
[3 markah]

Answer / Jawapan :

-
-
-

1

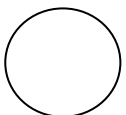
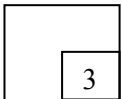

- 2 Given function g and h as $g(x) = 2x - 3$ and $h(x) = 2x^2 + 2$. Find $hg(x)$.
 Fungsi g dan h diberi sebagai $g(x) = 2x - 3$ dan $h(x) = 2x^2 + 2$. Cari $hg(x)$.

[3 marks]

[3 markah]

Answer / Jawapan :

For
examiner's
use only

2

2
3

- 3 Find $f^{-1}(x)$ given $f(x) = -2x + 10$.
 Cari $f^{-1}(x)$ diberi $f(x) = -2x + 10$.

[2 marks]

[2 markah]

Answer / Jawapan :

3

3
2

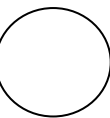

For
examiner's
use only

- 4 Find the values of k if $x^2 + 2kx + 2 - k = 0$ has two equal roots.
Cari nilai-nilai k jika $x^2 + 2kx + 2 - k = 0$ mempunyai dua punca sama.

[3 marks]

[3 markah]

Answer /Jawapan:

4

3

- 5 Find the range of values of x for $(x - 4)^2 < 6 - x$.
Cari julat nilai x bagi $(x - 4)^2 < 6 - x$.

[3 marks]

[3 markah]

Answer/Jawapan

5

3

- 6 Solve the equation $\sqrt{27^{x+2}} = \frac{1}{9^{1-x}}$.
 Selesaikan persamaan $\sqrt{27^{x+2}} = \frac{1}{9^{1-x}}$.

[3 marks]
 [3 markah]

Answer / Jawapan:

For
 examiner's
 use only

6



- 7 Given that $\log_3 p = x$ and $\log_3 q = y$, express $\log_9 \frac{81q}{p^2}$ in terms of x and y .

Diberi $\log_3 p = x$ dan $\log_3 q = y$, ungkapkan $\log_9 \frac{81q}{p^2}$ dalam bentuk x dan y .

[4 marks]
 [4 markah]

Answer / Jawapan :

7

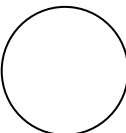

8. Diagram 8 shows the graph of the quadratic function $y = f(x)$. The straight line $y = -14$ is a tangent to the curve $y = f(x)$.
Rajah 8 menunjukkan fungsi kuadratik $y = f(x)$. Garis lurus $y = -14$ ialah tangen kepada lengkung $y = f(x)$.

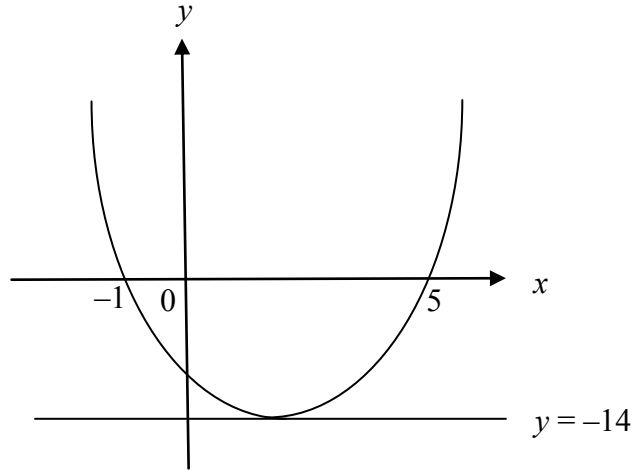

Diagram 8
Rajah 8

- (a) State the equation of the axis of symmetry of the curve.
Nyatakan persamaan paksi simetri bagi lengkung itu.
- (b) Express $f(x)$ in the form of $(x + p)^2 + q$, where p and q are constants.
Ungkapkan $f(x)$ dalam bentuk $(x + p)^2 + q$, di mana p dan q adalah pemalar.
- (c) Express $f(x)$ in general form.
Ungkapkan $f(x)$ dalam bentuk $ax^2 + bx + c$.

[3 marks]
 [3 markah]

Answer / Jawapan :

(a)

(b)

(c)

8

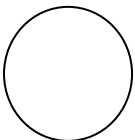
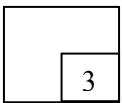

- 9 The sum of first n terms of an arithmetic progression is given by $S_n = 2n(9 - n)$.
Hasil tambah n sebutan pertama bagi suatu jangjang aritmetik diberi oleh $S_n = 2n(9 - n)$.

Find
Cari

- (a) the common difference,
beza sepunya,
- (b) the sum of the first 6 terms.
hasil tambah 6 sebutan pertama.

[4 marks]

[4 markah]

Answer / *Jawapan* :

(a)

(b)

9

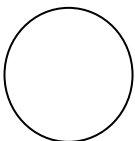
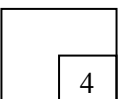

For
examiner's
use only

- 10 Given the geometric progression $-10, \frac{20}{3}, -\frac{40}{9}, \dots$, find the sum to infinity of the progression.

Diberi jangjang geometri $-10, \frac{20}{3}, -\frac{40}{9}, \dots$, cari hasil tambah hingga ketakterhinggaan jangjang itu.

[3 marks]
[3 markah]

Answer / Jawapan:

10

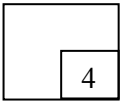

- 11 The vertices of a parallelogram are $(9, 8)$, $(9, 2)$, $(2, p)$ and $(4, 7)$. Given that its area is 40 unit^2 , find the values of p .

Bucu-bucu sebuah segi empat selari ialah $(9, 8)$, $(9, 2)$, $(2, p)$ dan $(4, 7)$. Diberi luasnya ialah 40 unit^2 . Cari nilai-nilai p .

[4 marks]
[4 markah]

Answer / Jawa pan:

11

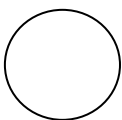
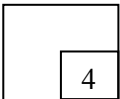

12.

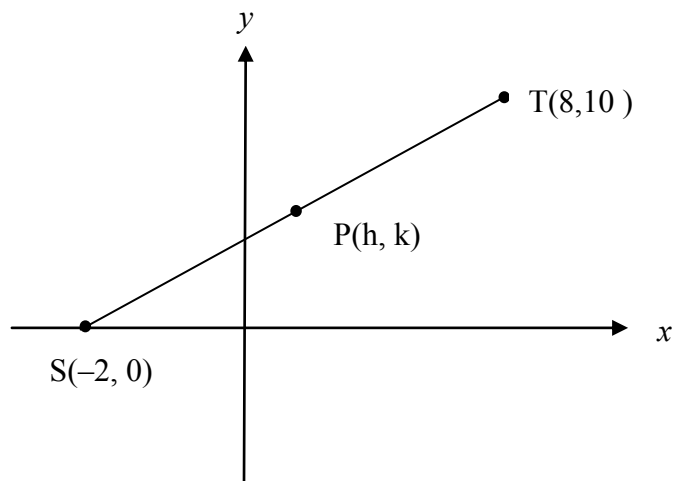

Diagram 12
Rajah 12

Diagram 12 shows a straight line ST . Point P lies on ST such that $SP : PT = 2 : 3$. Find the coordinates of P .

Rajah 12 menunjukkan garis lurus ST . Titik P terletak di atas ST dengan keadaan $SP : PT = 2 : 3$. Cari koordinat P .

[3 marks]
[3 markah]

Answer/ Jawapan:

12

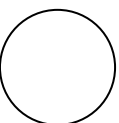
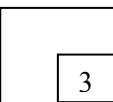

For
examiner's
use only

- 13 Diagram 13 shows the vectors $\vec{OA} = \underline{a}$ and $\vec{OB} = \underline{b}$
 Rajah 13 menunjukkan vektor $\vec{OA} = \underline{a}$ dan $\vec{OB} = \underline{b}$

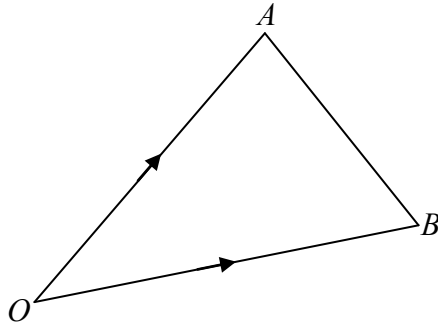

Diagram 13
Rajah 13

If C is the midpoint of AB , find \vec{OC}

Jika C adalah titik tengah AB , cari \vec{OC} .

[2 marks]
[2 markah]

Answer / Jawapan:

13

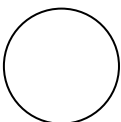
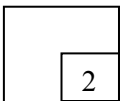

14 Given that $\vec{AB} = \begin{pmatrix} -5 \\ m \end{pmatrix}$ and $\vec{CD} = \begin{pmatrix} -2 \\ k \end{pmatrix}$, find

Diberi $\vec{AB} = \begin{pmatrix} -5 \\ m \end{pmatrix}$ dan $\vec{CD} = \begin{pmatrix} -2 \\ k \end{pmatrix}$, cari

(a) the value of m , where $m > 0$, if the unit vector in the direction of \vec{AB} is $-\frac{5}{13}\vec{i} + \frac{12}{13}\vec{j}$

nilai m , dengan keadaan $m > 0$, jika vektor unit dalam arah \vec{AB} ialah $-\frac{5}{13}\vec{i} + \frac{12}{13}\vec{j}$

(b) the value of k , if \vec{AB} is parallel to \vec{CD} .
nilai k , jika \vec{AB} selari dengan \vec{CD} .

[3 marks]
[3 markah]

Answer/ Jawapan:

(a)

(b)

14

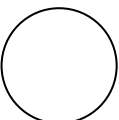
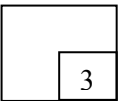

For
examiner's
use only

15 Diagram 15 shows a straight line graph of $\frac{y}{x}$ against $\frac{1}{x^2}$. Express y in terms of x .

Rajah 15 menunjukkan graf garis lurus $\frac{y}{x}$ melawan $\frac{1}{x^2}$. Ungkapkan y dalam sebutan x .

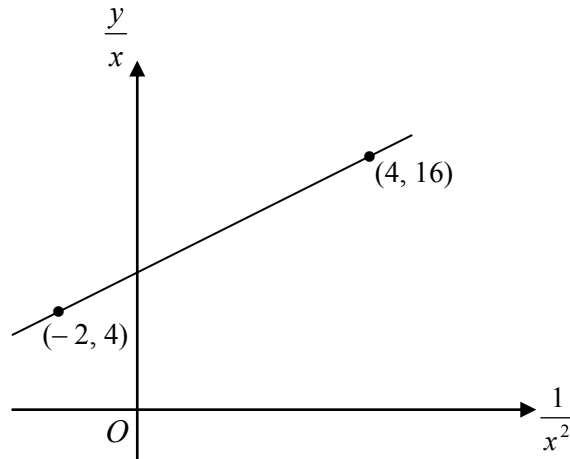
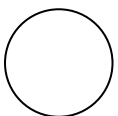
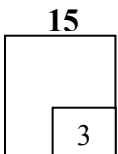

Diagram 15
Rajah 15

[3 marks]
[3 markah]

Answer / Jawapan:



- 16 Given that $\sin A = -\frac{3}{5}$ and $\tan B = \frac{5}{12}$ such that angle A and B lie on the same quadrant. Evaluate $\cos (A + B)$. [3 marks]

Diberi bahawa $\sin A = -\frac{3}{5}$ dan $\tan B = \frac{5}{12}$ di mana sudut A dan sudut B berada pada sukuan yang sama. Nilaikan $\cos (A + B)$. [3 markah]

Answer / Jawapan:

16



- 17 Solve the equation $6 \sec^2 x - 13 \tan x = 0$, for $0^\circ \leq x \leq 360^\circ$.
Selesaikan persamaan $6 \sec^2 x - 13 \tan x = 0$, bagi $0^\circ \leq x \leq 360^\circ$.

[4 marks]
[4 markah]

Answer / Jawapan:

17

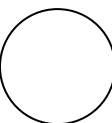
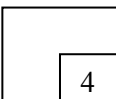

- 18 Diagram 18 shows two sectors OAB and OCD of circles with centre O .
Rajah 18 menunjukkan dua sektor OAB dan OCD sebuah bulatan berpusat di O .

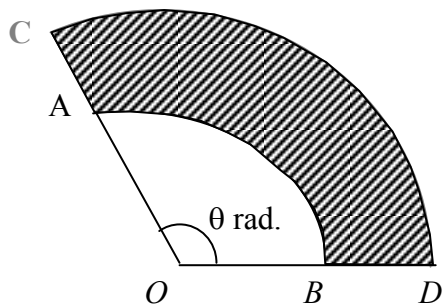

Diagram 18
Rajah 18

Given $\angle AOB = \theta$ radian, arc length AB is twice the length of radius OB and radius $OD = 6$ cm.

Diberi $\angle AOB = \theta$ radian, panjang lengkok AB dua kali panjang jejari OB dan $OD = 6$ cm.

Find,
Cari

- (a) the value of θ ,
nilai θ ,
- (b) perimeter of the shaded region.
perimeter kawasan berlorek.

[4 marks]
[4 markah]

Answer / *Jawapan:*

(a)

(b)

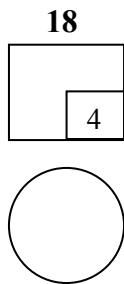

- 19 Given the equation of the curve, $y = 2x^2 - 16x + 25$.
Diberi persamaan lengkung, $y = 2x^2 - 16x + 25$.

Find,
Cari

- (a) the coordinate $-x$ of turning point.
koordinat $-x$ bagi titik pertukaran.
- (b) the equation of tangent at point $A (3, 4)$.
persamaan tangen pada titik $A (3,4)$

[4 marks]
[4 markah]

Answer / *Jawapan:*

(a)

(b)

19

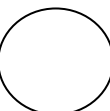
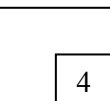

20 Given that $\int_0^4 f(x) dx = 5$ and $\int_1^3 g(x) dx = 6$.

Di beri bahawa $\int_0^4 f(x) dx = 5$ dan $\int_1^3 g(x) dx = 6$.

Find the value of,

Cari nilai bagi,

(a) $\int_0^4 2f(x)dx + \int_3^1 g(x)dx$,

(b) k if $\int_1^3 [g(x) - kx]dx = 14$.

[3 marks]

[3 markah]

Answer / Jawapan:

(a)

(b)

20



21 A set of data consists of 10 numbers. The sum of the numbers is 150.

Satu set data mempunyai 10 nombor. Hasil tambah nombor-nombor tersebut ialah 150.

(a) Find the mean

Cari min.

(b) A number p is added to the set of data, the new mean is increased by 1.

Find, the value of p .

Satu nombor p ditambahkan kepada set data ini, min baru bertambah sebanyak 1.

[3 marks]

[3 markah]

Answer / Jawapan:

(a)

(b)

21

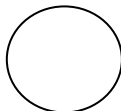
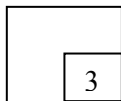

22. Diagram 22 shows nine letter cards.
Rajah 22 menunjukkan sembilan keping kad huruf.

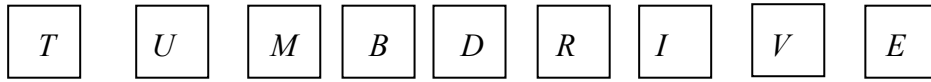

Diagram 22
Rajah 22

A five -letter code is to be formed by using five of these cards.
Suatu kod lima huruf hendak dibentuk dengan menggunakan lima daripada kad-kad ini.

Find,
Cari,

- (a) the number of different five -letter codes that can be formed,
bilangan kod lima huruf yang berlainan yang dapat dibentuk.
- (b) the number of different five -letter codes which begin with a vowel and end with a consonant.
bilangan kod lima huruf yang berlainan yang berlainan yang bermula dengan huruf vokal dan berakhir dengan konsonan.

[4 marks]
[4 markah]

Answer / *Jawapan:*

(a)

(b)

22

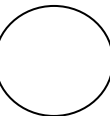
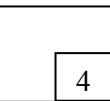

- 23 Ah Chong and Abu compete in a game which has two outcomes, win or lose. The game will end when any of the players has won two sets. The probability that

Ah Chong will win any one set is $\frac{3}{5}$.

Ah Chong dan Abu bertanding dalam satu permainan yang mempunyai dua kesudahan, menang atau kalah. Permainan akan berakhir apabila salah seorang menang dua set permainan. Kebarangkalian Ah Chong menang salah satu permainan ialah $\frac{3}{5}$

Calculate the probability that
Kira kebarangkalian bahawa.

- (a) the game will end in only two set,
permainan akan berakhir dalam dua set sahaja.
- (b) Ah Chong will win the competition after playing 3 sets.
Ah Chong akan menang permainan itu selepas bermain 3 set.

[4 marks]

[4 markah]

Answer / Jawapan:

(a)

(b)

23

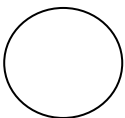
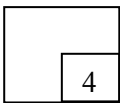

- 24 The probability of a student having laptop in a particular class is p . Given that the mean and the standard deviation of the number of students having laptops are 18 and $\sqrt{\frac{36}{5}}$ respectively. Find the value of p .

Kebarangkalian seorang pelajar mempunyai komputer riba dalam suatu kelas ialah p . Diberi bahawa min dan sisihan piawai bilangan pelajar yang mempunyai komputer riba ialah 18 dan $\sqrt{\frac{36}{5}}$ masing – masing. Cari nilai p

[3 marks]

[3 markah]

Answer / Jawapan:

24

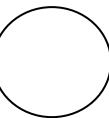

For
examiner's
use only

- 25 The length of the pen produced by a factory are normally distributed with a mean of 14 cm and a standard deviation of 0.1 cm. Diagram 25 shows the normal distribution graph for the length of the pen, X cm.
Panjang bagi sebatang pen dari sebuah kilang adalah tertabur secara normal dengan min 14 cm dan sisihan piawai 0.1 cm. Rajah 25 menunjukkan graf taburan normal untuk panjang pen, X cm.

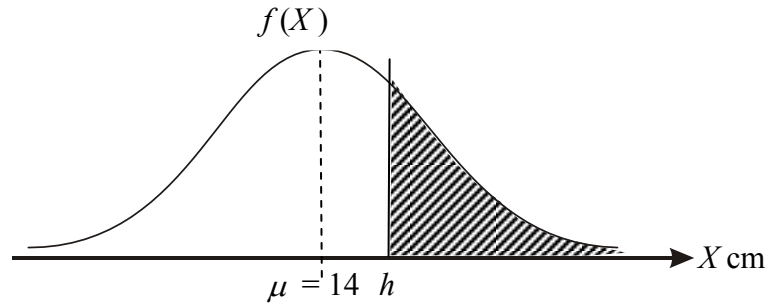

Diagram 25
Rajah 25

It is given that the area of the shaded region is 0.4483. Find the value of h .
Diberi luas kawasan berlorek ialah 0.4483. Cari nilai h

[3 marks]
[3 markah]

Answer / Jawapan:

25

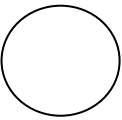
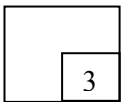

END OF THE QUESTION PAPER
KERTAS SOALAN TAMAT



**MAJLIS PENGETUA SEKOLAH MALAYSIA
CAWANGAN MELAKA
PEPERIKSAAN PERCUBAAN TINGKATAN LIMA 2012**

MATEMATIK TAMBAHAN

Kertas 2

Dua jam tiga puluh minit

JANGAN BUKA KERTAS SOALAN INI SEHINGGA DIBERITAHU

1. ***This question paper consists of three sections : Section A, Section B and Section C***
Kertas soalan ini mengandungi tiga bahagian : Bahagian A, Bahagian B dan Bahagian C.
 2. ***Answer all questions in Section A, four questions from Section B and two questions from Section C.***
Jawab semua soalan dalam Bahagian A, empat soalan daripada Bahagian B, dan dua soalan daripada Bahagian C.
 3. ***Give only one answer/solution to each question.***
Bagi setiap soalan, berikan satu jawapan / penyelesaian sahaja.
 4. ***Show your working. It may help you to get marks.***
Tunjukkan langkah-langkah penting dalam kerja mengira anda. Ini boleh membantu anda untuk mendapatkan markah.
 5. ***The diagrams in the questions provided are not drawn to scale unless stated.***
Rajah yang mengiringi soalan tidak dilukiskan mengikut skala kecuali dinyatakan,
 6. ***The marks allocated for each question and sub-part of a question are shown in brackets***
Markah yang diperuntukkan bagi setiap soalan dan ceraian soalan ditunjukkan dalam kurungan.
 7. ***A list of formulae is provided on pages 2 and 3.***
Satu senarai rumus disediakan di halaman 2 dan 3.
 8. ***A booklet of four-figure mathematical tables is provided.***
Buku sifir matematik empat angka boleh digunakan.
 9. ***You may use a non-programmable scientific calculator.***
Anda dibenarkan menggunakan kalkulator saintifik yang tidak boleh diprogram.
-

Kertas soalan ini mengandungi 18 halaman bercetak

The following formulae may be helpful in answering the questions. The symbols given are the ones commonly used.

Rumus-rumus berikut boleh digunakan untuk membantu anda menjawab soalan. . Simbol-simbol yang diberi adalah yang biasa digunakan.

ALGEBRA

$$1 \quad x = \frac{-b \pm \sqrt{b^2 - 4ac}}{2a}$$

$$2 \quad a^m \times a^n = a^{m+n}$$

$$3 \quad a^m \div a^n = a^{m-n}$$

$$4 \quad (a^m)^n = a^{nm}$$

$$5 \quad \log_a mn = \log_a m + \log_a n$$

$$6 \quad \log_a \frac{m}{n} = \log_a m - \log_a n$$

$$7 \quad \log_a m^n = n \log_a m$$

$$8 \quad \log_a b = \frac{\log_c b}{\log_c a}$$

$$9 \quad T_n = a + (n-1)d$$

$$10 \quad S_n = \frac{n}{2}[2a + (n-1)d]$$

$$11 \quad T_n = ar^{n-1}$$

$$12 \quad S_n = \frac{a(r^n - 1)}{r - 1} = \frac{a(1 - r^n)}{1 - r}, \quad (r \neq 1)$$

$$13 \quad S_\infty = \frac{a}{1 - r}, \quad |r| < 1$$

CALCULUS (*Kalkulus*)

$$1 \quad y = uv, \quad \frac{dy}{dx} = u \frac{dv}{dx} + v \frac{du}{dx}$$

$$2 \quad y = \frac{u}{v}, \quad \frac{dx}{dy} = \frac{v \frac{du}{dx} - u \frac{dv}{dx}}{v^2},$$

$$3 \quad \frac{dy}{dx} = \frac{dy}{du} \times \frac{du}{dx}$$

$$4 \quad \text{Area under a curve}$$

(Luas dibawah lengkung)

$$= \int_a^b y \, dx \quad \text{or (atau)}$$

$$= \int_a^b x \, dy$$

$$5 \quad \text{Volume generated}$$

(Isipadu janaan)

$$= \int_a^b \pi y^2 \, dx \quad \text{or}$$

$$= \int_a^b \pi x^2 \, dy$$

GEOMETRY

$$1 \quad \text{Distance (Jarak)}$$

$$= \sqrt{(x_1 - x_2)^2 + (y_1 - y_2)^2}$$

$$2 \quad \text{Midpoint (Titik tengah)}$$

$$(x, y) = \left(\frac{x_1 + x_2}{2}, \frac{y_1 + y_2}{2} \right)$$

$$3 \quad |r| = \sqrt{x^2 + y^2}$$

$$4 \quad r = \frac{xi + yj}{\sqrt{x^2 + y^2}}$$

$$5. \quad \text{A point dividing segment of a line}$$

(Titik yang membahagi suatu tembereng garis)

$$(x, y) = \left(\frac{nx_1 + mx_2}{m+n}, \frac{ny_1 + my_2}{m+n} \right)$$

$$6. \quad \text{Area of triangle (Luas segitiga) =}$$

$$\frac{1}{2} |(x_1y_2 + x_2y_3 + x_3y_1) - (x_2y_1 + x_3y_2 + x_1y_3)|$$

STATISTICS (STATISTIK)

$$1 \quad \bar{x} = \frac{\sum x}{N}$$

$$2 \quad \bar{x} = \frac{\sum fx}{\sum f}$$

$$3 \quad \sigma = \sqrt{\frac{\sum (x - \bar{x})^2}{N}} = \sqrt{\frac{\sum x^2}{N} - \bar{x}^2}$$

$$4 \quad \sigma = \sqrt{\frac{\sum f(x - \bar{x})^2}{\sum f}} = \sqrt{\frac{\sum fx^2}{\sum f} - \bar{x}^2}$$

$$5 \quad m = L + \left[\frac{\frac{1}{2}N - F}{f_m} \right] C$$

$$6 \quad I = \frac{Q_1}{Q_0} \times 100$$

$$7 \quad \bar{I} = \frac{\sum w_1 I_1}{\sum w_1}$$

$$8 \quad {}^n P_r = \frac{n!}{(n-r)!}$$

$$9 \quad {}^n C_r = \frac{n!}{(n-r)!r!}$$

$$10 \quad P(A \cup B) = P(A) + P(B) - P(A \cap B)$$

$$11 \quad P(X=r) = {}^n C_r p^r q^{n-r}, \quad p + q = 1$$

$$12 \quad \text{Mean, } \mu = np$$

$$13 \quad \sigma = \sqrt{npq}$$

$$14 \quad z = \frac{x - \mu}{\sigma}$$

TRIGONOMETRY

$$1 \quad \text{Arc length, } s = r\theta$$

(Panjang lengkok, $s = j\theta$)

$$2 \quad \text{Area of sector, } A = \frac{1}{2}r^2\theta$$

(Luas sektor, $L = \frac{1}{2}j^2\theta$)

$$3 \quad \sin^2 A + \cos^2 A = 1$$

$$4 \quad \sec^2 A = 1 + \tan^2 A$$

$$5 \quad \text{cosec}^2 A = 1 + \cot^2 A$$

$$6 \quad \sin 2A = 2 \sin A \cos A$$

$$7 \quad \cos 2A = \cos^2 A - \sin^2 A$$

$$= 2 \cos^2 A - 1$$

$$= 1 - 2 \sin^2 A$$

$$8 \quad \tan 2A = \frac{2 \tan A}{1 - \tan^2 A}$$

$$9 \quad \sin(A \pm B) = \sin A \cos B \pm \cos A \sin B$$

($\sin(A \pm B) = \sin A \cos B \pm \cos A \sin B$)

$$10 \quad \cos(A \pm B) = \cos A \cos B \mp \sin A \sin B$$

($\cos(A \pm B) = \cos A \cos B \mp \sin A \sin B$)

$$11 \quad \tan(A \pm B) = \frac{\tan A \pm \tan B}{1 \mp \tan A \tan B}$$

$$12 \quad \frac{a}{\sin A} = \frac{b}{\sin B} = \frac{c}{\sin C}$$

$$13 \quad a^2 = b^2 + c^2 - 2bc \cos A$$

($a^2 = b^2 + c^2 - 2bc \cos A$)

$$14 \quad \text{Area of triangle (Luas segitiga)} = \frac{1}{2} ab \sin C$$

Section A
Bahagian A
[40 marks]
[40 markah]

Answer **all** questions in this section
Jawab **semua** soalan dalam bahagian ini.

- 1 Solve the simultaneous equation $2(x - y) = x + y + 1 = 2x^2 - 11y^2$. [6 marks]
Selesaikan persamaan serentak $2(x - y) = x + y + 1 = 2x^2 - 11y^2$. [6 markah]
- 2 Company Supper made a profit of RM 60 000 in the year 2008. The company's profit grew by 10.5% from year to year.
Syarikat Supper mendapat keuntungan RM 60 000 pada tahun 2008. Keuntungan syarikat itu meningkat sebanyak 10.5% setiap tahun.
- Calculate
Hitung
- (a) the profit, to the nearest RM, for the year 2012.
keuntungan, kepada RM terdekat, untuk tahun 2012. [2 marks]
[2 markah]
- (b) the minimum value of n such that the profit in the n^{th} year will exceed RM 300,000.
nilai minimum n dengan keadaan keuntungan tahunannya pada tahun ke- n akan melebihi RM 300,000. [3 marks]
[3 markah]
- (c) the total profit, to the nearest RM, made by the company from year 2008 to 2012.
jumlah keuntungan, kepada RM terdekat, yang diperoleh oleh syarikat itu dari tahun 2008 hingga 2012. [2 marks]
[2 markah]

- 3 (a) Sketch the graph of $y = |2 \tan 2x|$ for $0 \leq x \leq 2\pi$. [4 marks]
Lakarkan graf bagi $y = |2 \tan 2x|$ untuk $0 \leq x \leq 2\pi$. [4 markah]

- (b) Hence, using the same axes, sketch a suitable graph to find the number of Solutions to the equation $2 - |2 \tan 2x| = \frac{x}{2\pi}$ for $0 \leq x \leq 2\pi$.
State the number of solutions. [3 marks]

*Seterusnya, dengan menggunakan paksi yang sama, lakar satu graf yang sesuai untuk mencari bilangan penyelesaian bagi persamaan $2 - |2 \tan 2x| = \frac{x}{2\pi}$ untuk $0 \leq x \leq 2\pi$.
Nyatakan bilangan penyelesaian itu. [3 markah]*

- 4 The point R lies on the curve $y = (4x - 5)^2$. It is given that the gradient of the normal at R is $\frac{1}{8}$.

Titik R terletak pada lengkung $y = (4x - 5)^2$. Diberi bahawa kecerunan normal pada R ialah $\frac{1}{8}$.

Find
Cari

- (a) the coordinates of R . [4 marks]
koordinat R . [4 markah]
- (b) the equation of tangent at the point R . [2 marks]
persamaan tangen pada titik R . [2 markah]

5. Table 5 (i) shows the cumulative frequency distribution of the marks of 40 students.
Jadual 5 (i) menunjukkan taburan kekerapan longgokan markah bagi 40 orang murid.

Score <i>Skor</i>	< 20	< 30	< 40	< 50	< 60
Number of students <i>Bilangan murid</i>	6	10	20	34	40

Table 5 (i)
Jadual 5 (i)

- (a) Based on table 1, copy and complete the Table 5 (ii)
Berdasarkan Jadual 1, salin dan lengkapkan Jadual 5 (ii).

Score <i>Skor</i>	10 – 19	20 – 29	30 – 39	40 – 49	50 – 59
Number of students <i>Bilangan murid</i>					

Table 5 (ii)
Jadual 5 (ii)

[1 mark]
 [1 markah]

- (b) (i) State the modal class.
Nyatakan kelas mod.

- (ii) Using a scale of 2 cm to 10 marks on the horizontal axis and 2 cm to 2 students on the vertical axis, draw a histogram to represent the frequency distribution of the marks in table 5 (ii).

Hence, find the mode mark.

Dengan menggunakan skala 2 cm kepada 10 markah pada paksi mengufuk dan 2 cm kepada 2 orang murid pada paksi mencancang, lukis sebuah histogram bagi mewakili taburan kekerapan markah dalam jadual 5 (ii).

Seterusnya, cari markah mod.

[5 marks]
 [5 markah]

6. In Diagram 6, OAB is a triangle. P lies on OA such that $OP : PA = 2 : 1$ and Q lies on OB such that $OQ : QB = 3 : 1$. R is the point of intersection of the line AQ and BP .

Dalam Rajah 6, OAB ialah sebuah segi tiga. P terletak pada OA dengan keadaan $OP : PA = 2 : 1$ dan Q terletak pada OB dengan keadaan $OQ : QB = 3 : 1$. R ialah titik persilangan bagi garis AQ dan BP .

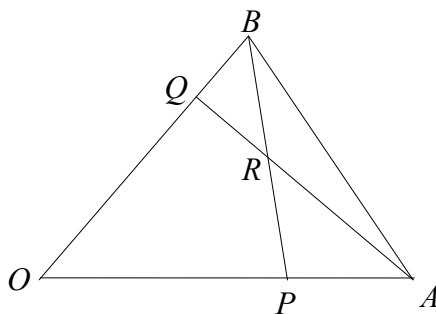

Diagram 6
Rajah 6

It is given $\vec{OA} = \underline{a}$ and $\vec{OB} = \underline{b}$

Diberi $\vec{OA} = \underline{a}$ dan $\vec{OB} = \underline{b}$

- (a) Find the following vectors.
Cari vector yang berikut.

(i) \vec{BP}

(ii) \vec{AQ}

[3 marks]

[3markah]

- (b) Using $\vec{BR} = h\vec{BP}$ and $\vec{AR} = k\vec{AQ}$, where h and k are constants, express \vec{BR} in terms of

Dengan menggunakan $\vec{BR} = h\vec{BP}$ dan $\vec{AR} = k\vec{AQ}$ dengan keadaan h dan k ialah pemalar, ungkapkan \vec{BR} dalam sebutan

(i) h, \underline{a} and \underline{b}

h, \underline{a} dan \underline{b}

(ii) k, \underline{a} and \underline{b}

k, \underline{a} dan \underline{b}

Hence, find the values of h and k ,
Seterusnya, cari nilai h dan nilai k

[5 marks]

Section B
Bahagian B
 [40 marks]
 [40 markah]

Answer **four** questions from this section.

Jawab empat soalan daripada bahagian ini.

7. Use graph paper to answer this question.
Gunakan kertas graf yang disediakan untuk menjawab soalan ini.

Table 7 shows the values of two variables, x and y , obtained from an experiment.

Variables x and y are related by the equation $y = \frac{k^{x+1}}{h}$, where h and k are constants.

Jadual 7 menunjukkan nilai-nilai bagi dua pemboleh ubah, x dan y , yang diperolehi daripada satu eksperimen. Pemboleh ubah x dan y dihubungkan oleh persamaan $y = \frac{k^{x+1}}{h}$ dengan keadaan h dan k adalah pemalar.

x	0.5	1.0	1.5	2.0	2.5	3.0
y	1.32	1.68	2.14	2.71	3.50	4.38

Table 7
Jadual 7

- (a) Based on table 7, construct a table for the values of $\log_{10} y$ and $(x+1)$. [2 marks]
Berdasarkan Jadual 7, bina satu jadual bagi nilai-nilai $\log_{10} y$ dan $(x+1)$. [2 markah]
- (b) Plot $\log_{10} y$ against $(x + 1)$, using a scale of 2 cm to 0.5 unit on the $(x+1)$ -axis and 2 cm to 0.1 on the $\log_{10} y$ -axis.
 Hence, draw the line of best fit. [3 marks]
*Plotkan $\log_{10} y$ melawan $(x + 1)$, dengan menggunakan skala 2 cm kepada 0.5 unit pada paksi- $(x + 1)$ dan 2cm kepada 0.1 unit pada paksi- $\log_{10} y$.
 Seterusnya, lukiskan garis lurus penyuaian terbaik.* [3 markah]
- (c) Use your graph in 7 (b) to find the value of
Gunakan graf anda dari 7(b) untuk mencari nilai
- (i) k
 (ii) h [5 marks]
 [5markah]

8. Solution by scale drawing is not accepted.
Penyelesaian secara lukisan berskala tidak diterima.

In Diagram 8, the straight line BC has equation $2y + x + 6 = 0$. BC intersects the y -axis at point S and O is the origin.

Dalam Rajah 8, garis lurus BC mempunyai persamaan $2y + x + 6 = 0$. BC memotong paksi- y pada titik S dan O ialah titik asalan

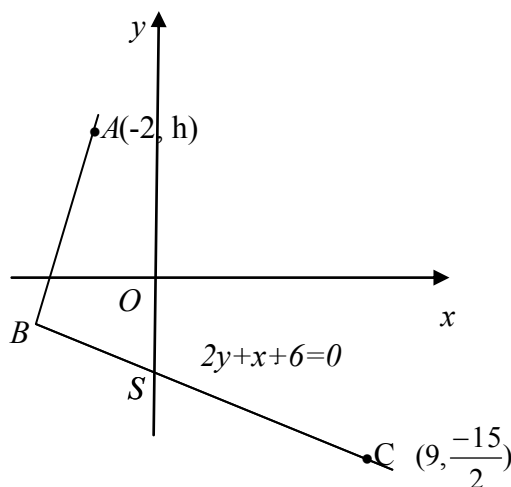

Diagram 8
Rajah 8

- (a) It is given that S lies on the straight line BC such that $BS : BC = 1 : 4$.
 Find the coordinates of B ,

[3 marks]

*Diberi bahawa S terletak pada garis lurus BC dengan keadaan $BS : BC = 1 : 4$.
 Cari koordinat B .*

[3markah]

- (b) Given the area of triangle OAB is 15 unit^2 , find the value of h .
Diberi luas segitiga OAB adalah 15 unit^2 , cari nilai h ,

[3 marks]

[3 markah]

- (c) A point P moves such that its distance from point S is half its distance from point A .
 Find the equation of the locus of P .

[4 marks]

*Satu titik P bergerak supaya jaraknya dari titik S ialah separuh jaraknya dari titik A .
 Cari persamaan locus P .*

[4 markah]

9. Diagram 9 shows a sector OPQ , centre O and a radius of 13 cm. SPT is another sector of a circle with centre S and a radius of 5 cm, which is inscribed in the sector OPQ such that ST is perpendicular to OQ .
Rajah 9 menunjukkan sebuah sektor OPQ , berpusat O dan berjajari 13 cm. SPT adalah sebuah sektor lain berpusat S dan berjajari 5 cm berterap dalam sektor OPQ dengan keadaan ST adalah berserenjang dengan OQ .

[Use/Guna $\pi = 3.142$]

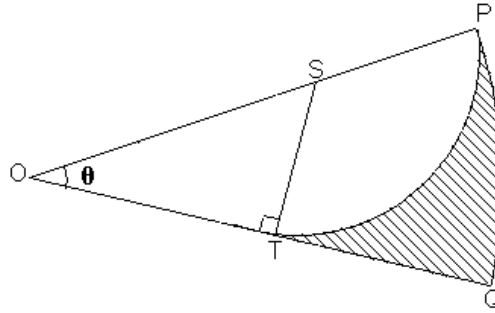

Diagram 9
Rajah 9

Calculate

Hitung

- | | |
|---|-------------------------|
| (a) the value of θ , in radians,
<i>nilai θ, dalam radian,</i> | [2 marks]
[2 markah] |
| (b) the perimeter, in cm, of the shaded region,
<i>perimeter, dalam cm, bagi kawasan berlorek,</i> | [4 marks]
[4 markah] |
| (c) the area, in cm^2 , of the shaded region.
<i>luas, dalam cm^2, bagi kawasan berlorek.</i> | [4 marks]
[4 markah] |

10. Diagram 10 shows part of the curve $y = f(x)$ which has gradient function $\frac{-4}{(2x-1)^3}$.

Rajah 10 menunjukkan sebahagian daripada lengkung $y = f(x)$ yang mempunyai fungsi kecerunan $\frac{-4}{(2x-1)^3}$.

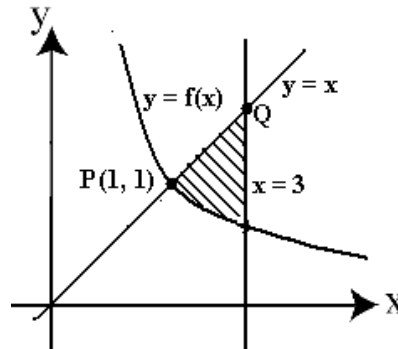

Diagram 10

Rajah 10

The curve intersects the straight line $y = x$ at point $P(1, 1)$.

Lengkung itu bersilang dengan garis lurus $y = x$ pada titik $P(1, 1)$

Find

Cari

- (a) the equation of the curve, [3 marks]
persamaan lengkung tersebut, [3 markah]
- (b) the area of the shaded region, [4 marks]
luas rantau berlorek, [4 markah]
- (c) the volume generated, in terms of π , when the region which is bounded by the curve, the x -axis and the straight lines $x = 1$ and $x = 3$, is revolved through 360° about the x -axis.

[3 marks]

isipadu yang dijanakan, dalam sebutan π , apabila rantau yang dibatasi oleh lengkung itu, paksi- x dan garis lurus $x = 1$ dan $x = 3$, dikisarkan melalui 360° pada paksi- x .

[3 markah]

11. (a) In a certain year, 80% of the students in a university graduated with honours.
If 10 of the students are selected at random, find the probability that
*Pada suatu tahun, 80% daripada pelajar di sebuah universiti lulus dengan kepujian.
Jika 10 orang daripada pelajar itu dipilih secara rawak, cari kebarangkalian bahawa*

(i) only one of the students did not graduate with honour.
hanya seorang pelajar tidak lulus dengan kepujian.

(ii) not more than two students did not graduate with honour.
kurang dua orang pelajar tidak lulus dengan kepujian..

[4 marks]

[4 markah]

(b) The masses of packets of coffee powder produced by a factory have a normal distribution with a mean of 200 g and a variance of 400 g.
Jisim serbuk kopi dalam paket yang dihasilkan oleh sebuah kilang adalah bertaburan secara normal dengan min 200 g dan varians 400 g.

(i) Find the probability that a packet of coffee selected randomly is more than 235 g.
Cari kebarangkalian bahawa sepeket serbuk kopi yang dipilih secara rawak adalah melebihi 235 g.

(ii) A random of 500 packets of coffee powder is chosen.
Given that from the sample 422 packets of coffee powder from the sample have a mass of more than m g. Find the value of m.
*Satu sampel rawak 500 peket serbuk kopi dipilih.
Diberi 422 peket serbuk kopi daripada sampel itu mempunyai jisim melebihi m g.
Cari nilai m.*

[6 marks]

[6 markah]

Section C

Bahagian C

[20 marks]

[20 markah]

Answer **two** questions from this section.Jawab **dua** soalan daripada bahagian ini.

12. Table 12 shows the prices in the year 2009 and 2010 of four types of local food.
Jadual 12 menunjukkan harga bagi empat jenis makanan tempatan untuk tahun 2009 dan 2010.

Food <i>Makanan</i>	Price per kilogram (RM) <i>Harga per kilogram(RM)</i>		Price index for the year 2010 based on the year 2009 <i>Indeks harga pada tahun 2010 berdasarkan tahun 2009</i>	Weightage <i>Pemberat</i>
	2009	2010		
<i>P</i>	2.80	2.10	<i>a</i>	4
<i>Q</i>	4.00	4.80	120	2
<i>R</i>	2.00	<i>b</i>	130	3
<i>S</i>	<i>c</i>	5.80	116	<i>m</i>

Table 12

Jadual 12

- (a) Find the value of

Cari nilai(i) *a*,(ii) *b*,(iii) *c*.

[3 marks]

[3 markah]

- (b) The composite index for the price of the food in the year 2010 based on the year 2009 is 108.4 . Calculate the value of
- m*
- .

[3 marks]

Indeks gubahan bagi harga makanan tersebut pada tahun 2010 berdasarkan tahun 2009 ialah 108.4 Hitung nilai m.

[3 markah]

- (c) The total cost for the food in the year 2009 is RM525. Calculate the total cost in the year 2010.

[2 marks]

Jumlah kos makanan tersebut pada tahun 2009 ialah RM525. Hitung jumlah kos bagi tahun 2010.

[2 markah]

- (d) The price index for
- Q*
- in the year 2011 based on the year 2009 is 132. Calculate the price index for
- Q*
- in the year 2011 based on the year 2010.

[2 marks]

Indeks harga bagi Q pada tahun 2011 berdasarkan tahun 2009 ialah 132. Hitung indeks harga bagi Q pada tahun 2011 berasaskan tahun 2010.

[2markah]

13. A particle moves along a straight line and passes through a fixed point O . Its velocity, $v \text{ ms}^{-1}$, is given by $v = t^2 - 10t + 24$, where t is the time, in seconds, after passing through O .

Suatu zarah bergerak di sepanjang suatu garis lurus melalui satu titik tetap O . Halaju zarah itu, $v \text{ ms}^{-1}$, diberi oleh $v = t^2 - 10t + 24$, dengan keadaan t ialah masa dalam saat selepas melalui O .

[Assume motion to the right is positive].

[Anggapkan gerakan ke arah kanan sebagai positif]

Find

Cari

- (a) the initial velocity, in ms^{-1} . [1 mark]
halaju awal, dalam ms^{-1} . [1markah]
- (b) the minimum velocity, in ms^{-1} . [3 marks]
halaju minimum, dalam ms^{-1} . [3markah]
- (c) the range of t during which the particle moves to the left. [2 marks]
julat nilai t ketika zarah bergeak kea rah kiri. [2 markah]
- (d) The total distance, in m, travelled by the particle in the first 5 seconds. [4 marks]
Jumlah jarak, dalam m, yang dilalui oleh zarah dalam 5 saat pertama. [4 markah]

14. Use the graph paper provided to answer this question.

Gunakan kertas graf yang disediakan untuk menjawab soalan ini.

Model	Machine A(minutes) <i>Mesin A (minit)</i>	Machine B (minutes) <i>Mesin B (minit)</i>
<i>P</i>	8	5
<i>Q</i>	18	8

Table 14
Jadual 15

Table 14 shows time taken by machine *A* and machine *B* to produce two types of toys of model *P* and model *Q*. The factory production is based on the following constraints
Jadual 14 menunjukkan masa yang digunakan oleh mesin A dan mesin B untuk menghasilkan dua jenis alat permainan iaitu model P dan model Q. Kilang telah menetapkan syarat-syarat seperti berikut

- I Machine *A* operates at least 720 minutes per day.
Mesin A beroperasi sekurang-kurangnya 720 minit sehari.
- II Machine *B* operates at most 800 minutes per day.
Mesin B beroperasi tidak melebihi 800 minit sehari
- III The ratio of the number of model *Q* toy to the number of model *P* toy is not more than 5 : 8.
Nisbah bilangan alat permainan model Q terhadap bilangan alat permainan model P tidak melebihi 5 : 8.

The factory produced x model *P* toy and y model *Q* toy.

Kilang itu mengeluarkan x buah alat permainan model P dan y buah alat per mainan model Q.

- (a) Write three inequalities, other than $x \geq 0$ and $y \geq 0$, which satisfy all the above constraints.

Tuliskan tiga ketaksamaan selain daripada $x \geq 0$ dan $y \geq 0$ yang memuaskan syarat-syarat di atas.

[3 marks]

[3 markah]

- (b) Using the scale of 2 cm to 20 toys on the x -axis and 2 cm to 10 toys on y -axis, construct and shade the region *R* which satisfies all of the above inequalities.

Dengan menggunakan skala 2 cm kepada 20 alat permainan pada paksi-x dan 2 cm kepada 10 buah alat permainan pada paksi-y, bina dan lorekkan rantau R yang memuaskan kesemua ketaksamaan itu

[3marks]

[3 markah]

- (c) Using your graph from (b), find

Dengan menggunakan graf anda dari (b), cari

- (i) the maximum and minimum number of model *P* toys produced if 25 model *Q* toys was produced.

bilangan maksimum dan minimum alat permainan model P yang dihasilkan jika 25 buah alat permainan model Q dihasilkan.

- (ii) the maximum total amount gained by the factory if one model *P* and model *Q* toy is sold at the price of RM10 and RM30 respectively.

jumlah jualan maksimum yang diperolehi oleh kilang itu jika sebuah alat permainan model P dan model Q masing-masing dijual dengan harga RM10 dan RM30.

[4 marks]

[4markah]

15. Diagram 15 shows triangles LRM and LNM .

Rajah 15 menunjukkan segitiga LRM dan LNM .

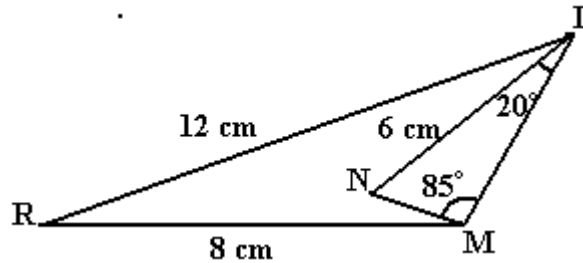

Diagram 15

Rajah 15

It is given that $RL = 12$ cm, $LN = 6$ cm and $MR = 8$ cm. $\angle NLM = 20^\circ$ and $\angle LMN = 85^\circ$

Diberi bahawa $RL = 12$ cm, $LN = 6$ cm dan $MR = 8$ cm. $\angle NLM = 20^\circ$ dan $\angle LMN = 85^\circ$

Calculate

Hitung

- (a) the length, in cm, of LM , [3 marks]
panjang, dalam cm, bagi LM , [3 markah]
- (b) $\angle RLN$, [3 marks]
[3 markah]
- (c) the area, in cm^2 , of quadrilateral $RLNM$. [4 marks]
luas, dalam cm^2 , bagi sisiempat $RLNM$. [4 markah]

END OF QUESTION PAPER

KERTAS SOALAN TAMAT

SULIT
3472/1
Additional
Mathematics
Paper 1
Ogos
2012



Majlis Pengetua-Pengetua Melaka
PEPERIKSAAN PERCUBAAN SIJIL PELAJARAN MALAYSIA 2012

ADDITIONAL MATHEMATICS

Paper 1

MARKING SCHEME

This marking scheme consists of 6 printed pages

<http://edu.joshuatly.com/>
<http://fb.me/edu.joshuatly>

PAPER1

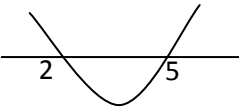
QUESTION NUMBERS	WORKING	MARKS	FULL MARKS
1	a) $m = 2$ b) $n = 6$ c) 20	1 1 1	3
2	$8x^2 - 24x + 20$ $2(4x^2 - 12x + 9) + 2$ $2(2x - 3)^2 + 2$	3 B2 B1	3
3	$f^{-1}(x) = \frac{10-x}{2}$ $10 - y = 2x$	2 B1	2
4	$k = -2, k = 1(\text{both})$ $(k-1)(k+2)=0$ $(2k)^2 - 4(1)(2-k)=0$	3 B2 B1	3
5	$2 < x < 5$ $(x-2)(x-5) < 0$ or  $x^2 - 7x + 10 < 0$	3 B2 B1	3
6	$x = 10$ $\frac{3}{2}x + 3 = -2 + 2x$ $3^{3(x+2)}$ or $3^{2(1-x)}$	3 B2 B1	3
7	$\frac{4+y-2x}{2}$ $\frac{4\log_3 3 + \log_3 q - 2\log_3 p}{2}$ $\frac{\log_3 3^4 + \log_3 q - \log_3 p^2}{2}$ $\frac{\log_3 \frac{81q}{p^2}}{\log_3 9}$	4 B3 B2 B1	
8	a) $x = 2$ b) $(x-2)^2 - 14$ c) $x^2 - 4x - 10$	1 1 1	3

QUESTION NUMBERS	WORKING	MARKS	FULL MARKS
9	(a) -4 $28 - 2(16)$ or $S_2 - 2 S_1$ $T_1 = 16$ (b) 36	3 B2 B1 1	4
10	-6 $\frac{-10}{1 - \frac{20}{3}(-\frac{1}{10})}$ $r = -\frac{2}{3}$	3 B2 B1	3
11	$p = -1$ and $p = 31$ $5p - 75 = 80$ or $5p - 75 = -80$ $\frac{1}{2} \begin{vmatrix} 9 & 9 & 2 & 4 & 9 \\ 8 & 2 & p & 7 & 8 \end{vmatrix} = 40$	3 B2 B1	3
12	$P(2, 4)$ $h = \frac{10}{5}$ or $k = \frac{20}{5}$ $h = \frac{2(8) + 3(-2)}{5}$ or $\frac{3(0) + 2(10)}{5}$	3 B2 B1	3
13	$\vec{OC} = \frac{1}{2}\vec{a} + \frac{1}{2}\vec{b}$ $\vec{OC} = \vec{OA} + \frac{1}{2}\vec{AB}$ OR $\vec{OC} = \vec{OB} + \frac{1}{2}\vec{AB}$	2 B1	2
14	(a) $m = 12$ (b) $k = \frac{24}{5}$ $\frac{m}{-5} = \frac{k}{2}$	1 2 B1	3

QUESTION NUMBERS	WORKING	MARKS	FULL MARKS
15	$y = \frac{2}{x} + 8x$ $\frac{y}{x} = 2\left(\frac{1}{x^2}\right) + c$ $16 = 2(4) + C \text{ or } 4 = 2(-2) + C \text{ or Gradient} = 2$	3 B2 B1	3
16	$\frac{33}{65}$ $\left(-\frac{4}{5}\right)\left(-\frac{12}{13}\right) - \left(-\frac{3}{5}\right)\left(-\frac{5}{13}\right)$ $\cos A = -\frac{4}{5} \text{ or } \cos B = -\frac{12}{13} \text{ or } \sin B = -\frac{5}{13}$	3 B2 B1	3
17	$x = 56^\circ 19', 236^\circ 19', 33^\circ 41', 213^\circ 41'$ <p>or $x = 56.31^\circ 236.31^\circ 33.69^\circ 213.69^\circ$</p> $x = 56^\circ 19' 33^\circ 41'$ $(2 \tan x - 3)(3 \tan x - 2) = 0$ $6(1 + \tan^2 x) - 13 \tan x = 0$	4 B3 B2 B1	4
18	<p>(a) $\theta = 2$ radian</p> $r\theta = 2r$ <p>(b) 24 cm</p> $12 - 2OB + 2OB + 12$	2 B1 2 B1	4
19	<p>(a) 4</p> $\frac{dy}{dx} = 4x - 16$ $y = -4x + 16$ <p>(b) $\frac{dy}{dx} = 4(3) - 16 = -4$</p>	2 B1 2 B1	4
20	<p>(a) 4</p> <p>(b) $k = -2$</p> $6 - \left[\frac{kx^2}{2}\right]_1^3$	1 2 B1	3

QUESTION NUMBERS	WORKING	MARKS	FULL MARKS
21	(a) 15 (b) 26 $\frac{150+x}{11} = 16$	1 2 B1	3
22	(a) 15120 9P_5 (b) 3780 $\underline{3} \times \underline{7} \times \underline{6} \times \underline{5} \times \underline{6} \text{ or } 3 \times {}^7P_3 \times 6$	2 B1 2 B1	4
23	a) $\frac{13}{25}$ $\frac{3}{5} \times \frac{3}{5} + \frac{2}{5} \times \frac{2}{5}$ b) $\frac{36}{125}$ $\frac{3}{5} \times \frac{2}{5} \times \frac{3}{5} + \frac{2}{5} \times \frac{3}{5} \times \frac{3}{5}$	2 B1 2 B1	4
24	$p = \frac{3}{5}$ $18q = \frac{36}{5}$ $\sqrt{npq} = \sqrt{\frac{36}{5}}$	3 B2 B1	3
25	14.013 $\frac{h-14}{0.1} = 0.13$ $P(z > \frac{h-14}{0.1}) = 0.4483$	3 B2 B1	3